



Connected Industrial Sensor Solution | CISS

The Robust Acceleration, Vibration & Condition Detector

The CISS is a multi-sensor device detecting acceleration and vibration as well as environmental conditions. The robust housing and the small outline makes it perfectly suitable for industrial retrofit applications such as condition monitoring and predictive maintenance. Configuring the device enables the customer to address a broad variety of use cases by interpreting the sensor data by smart algorithms.

BUILT-IN SENSORS

							
Accelerometer	Temperature sensor	Humidity sensor	Digital light sensor	Gyroscope	Magnetometer	Pressure sensor	Microphone

USE CASES

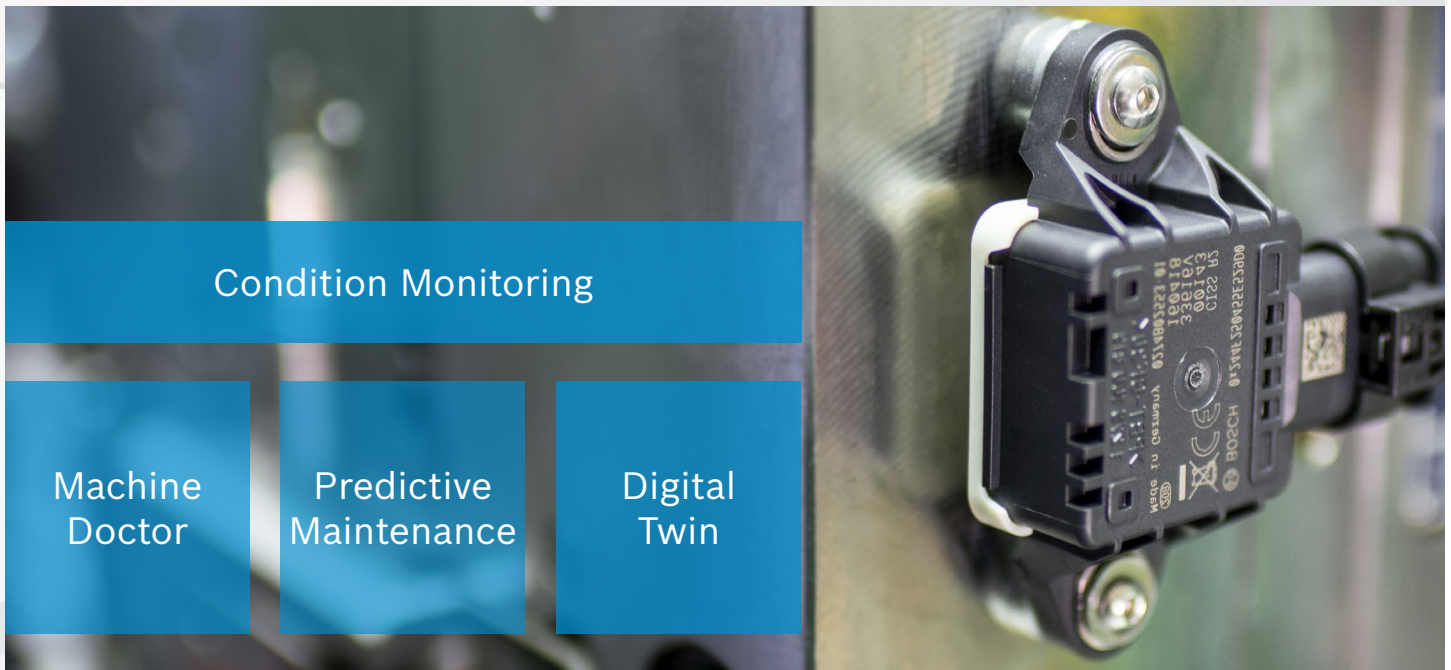

SCOPE OF DELIVERY

- ▶ CISS device with a small form factor
- ▶ USB cable (2m)
- ▶ Fasteners (2 screws, 2 washers, and 2 magnetic bases)
- ▶ Quick Start Guide

DOWNLOADS

- ▶ Example Python script
- ▶ Demo App: Virtual CISS
- ▶ Windows Driver
- ▶ Firmware Updates

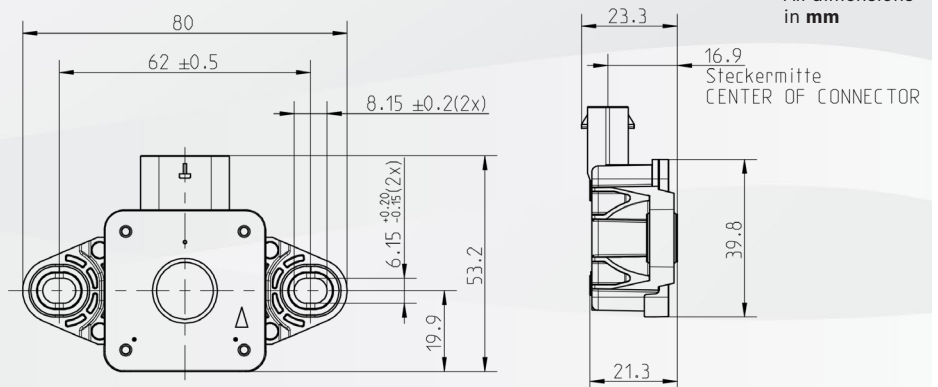

MAIN COMPONENTS

- ▶ Bluetooth Low Energy (BLE) radio
- ▶ 32-Bit microcontroller (ARM Cortex M3), 1MB Flash, 128 kB RAM
- ▶ User data memory 2MB
- ▶ Accelerometer BMA280, Gyroscope BMG160, Magnetometer BMC150, Temperature sensor, Humidity sensor, Air pressure sensor BME280, Light sensor MAX44009, Microphone AKU340



BOSCH
Invented for life

OPERATING CONDITIONS

- ▶ Operating temperature range -20 °C – 80 °C
- ▶ Humidity range 10 – 90 %rH (non-condensing)
- ▶ Pressure range 300 – 1100 hPa
- ▶ IP rating IP54
- ▶ Supply voltage 5 V DC

MEASUREMENT RANGES & ACCURACIES

Sensor	Measurement Range	Accuracy
▶ Accelerometer	± 2, 4, 8, 16 g (14 bit resolution)	± 50 mg
▶ Gyroscope	± 2000 °/s	± 1 °/s
▶ Magnetometer	±1300 μT (X,Y-Axis); ±2500μT (Z-Axis)	0.06 x M ± 25μT
▶ Temperature	-20 °C – 80 °C	max. ±2 °C + 3% T °C
▶ Humidity	20 – 90% (non-condensing)	max. ±7% at +20 °C, max. ±10% at -20 °C
▶ Pressure	300 - 1100 hPa	± 1.5 hPa
▶ Light	0 - 2112800 Lux	± 15 %

SAMPLING RATE (USB)*

- ▶ Inertial sensors ≤ 100 Hz
Accelerometer, Gyroscope, Magnetometer
- ▶ Environmental sensors ≤ 1 Hz
Temperature sensor, Humidity sensor, Air pressure sensor, Light sensor, Microphone

* Inertial sensor special mode: 2kHz streaming Accelerometer (without Gyroscope, Magnetometer and environmental data)

Hints: BLE sampling rate depends on the quality of the BLE connection; Microphone data can only be transferred via BLE.

INTERFACE

- ▶ USB communication protocol
- ▶ Bluetooth Low Energy communication protocol

GET IN CONTACT WITH US!

E-Mail: support@bosch-connectivity.com

Website: www.bosch-connectivity.com/CISS

Technical data subject to modification without notice.

© Bosch Connected Devices and Solutions GmbH 2017. All rights reserved, also regarding and disposal, exploitation, reproduction, editing, distribution, as well as in the event of application for industrial property rights. July, 04, 2018